

[1] Workspace

i Installation in the trunk near the left wheel arch.



[2] Exposed access to the inner space of the left wheel arch.

! Carefully remove the plastic cover side - at least as shown in the photo. Keep an eye to all the snaps around the perimeter of the fixing and to the screw under the eyelet bracket on this wall.

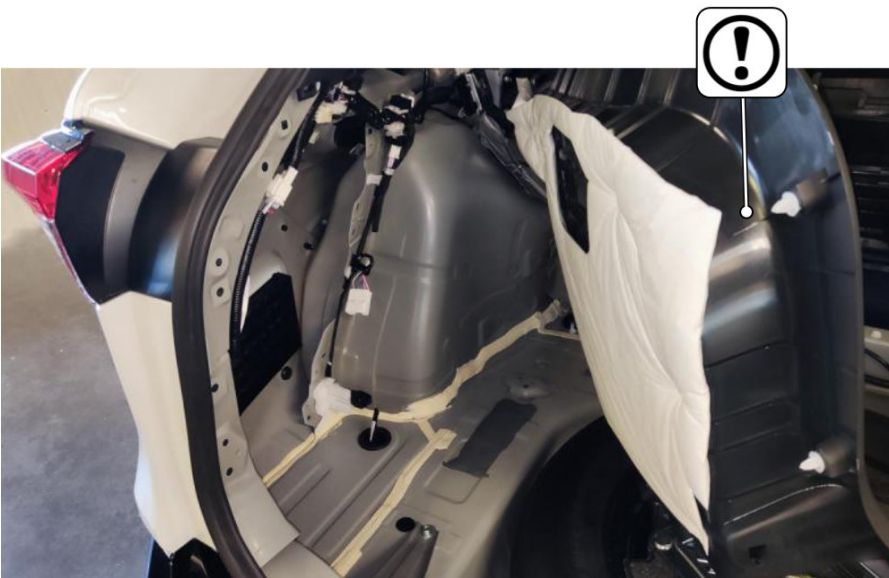

[3] Connection of TBM cable harness.

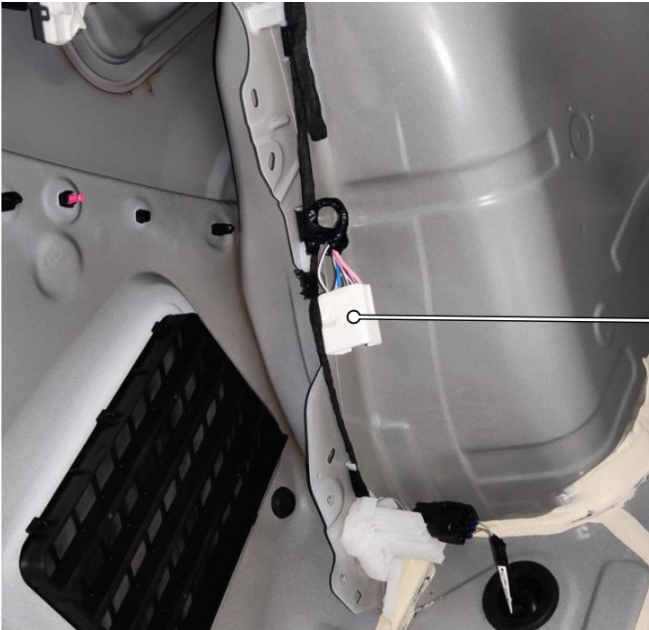

1 Factory connector for connection of the main plug TBM cable-harness.

[4] Finding the FOG light wire.



13 You will need by yourself to locate and identify the fog lamp wire (white and red - in the wires going up to the tailgate) and connect the blue wire from the TBM cable-harness to it.

13 EXCLUSIVELY for the "full" G13 harness, find the factory ground connection point just above the indicated location (the area of the wires going up to the tailgate) and attach there the "ground-eye" from the TBM cable-harness (this is the ground for the power pins in the trailer socket).

Connections description in trailer socket G8

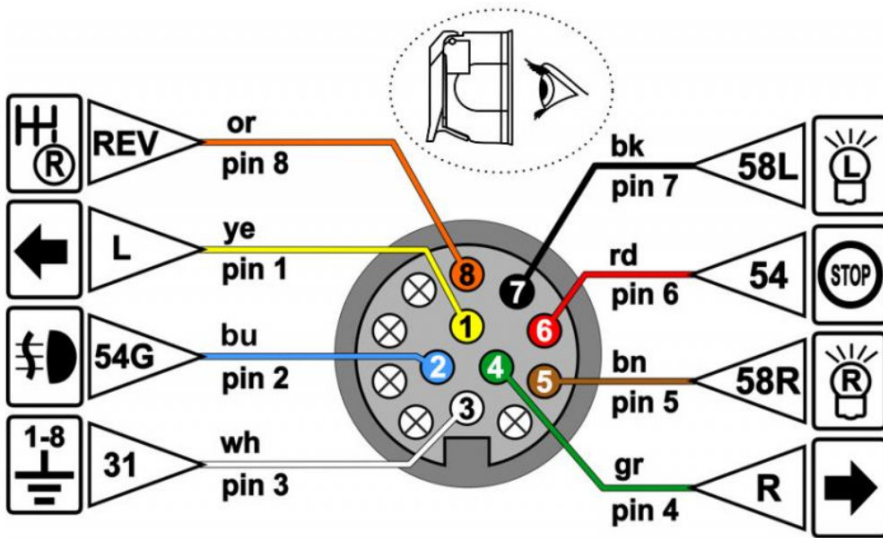

List of pins and colors	
i	pin 1 (ye) yellow
	pin 2 (bu) blue
	pin 3 (wh) white
	pin 4 (gr) green
	pin 5 (bn) brown
	pin 6 (rd) red
	pin 7 (bk) black
	pin 8 (or) orange

Connections description in trailer socket G13

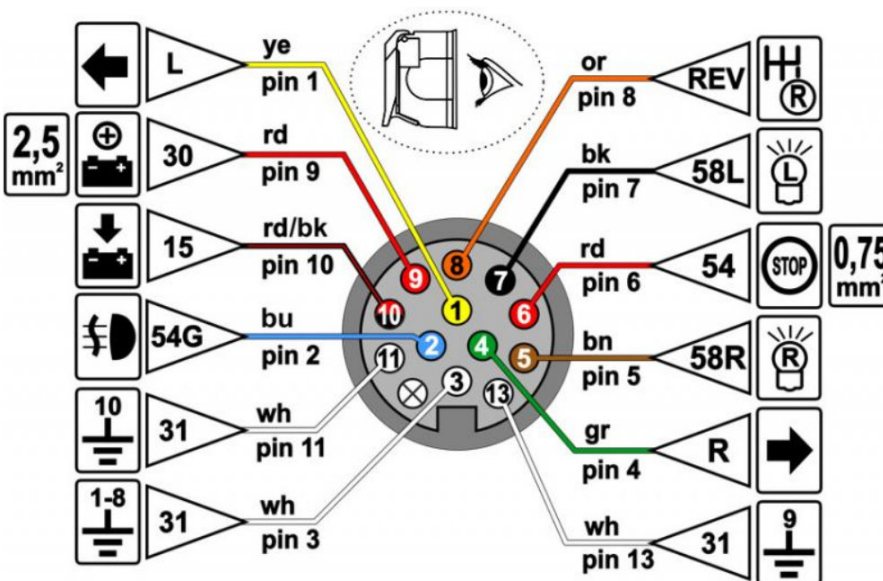

List of pins and colors	
i	pin 1 (ye) yellow
	pin 2 (bu) blue
	pin 3 (wh) white
	pin 4 (gr) green
	pin 5 (bn) brown
	pin 6 (rd) red
	pin 7 (bk) black
	pin 8 (or) orange
	pin 9 (rd) red
	pin10 (rd/bk) red/black
	pin11 (wh) white
	pin13 (wh) white